

# IL FUOCO 5.0





**h&Co.**  
MILANO

**#IOSONOILFUOCO**



## Stufe stagné Air Tight

Poêles étanches  
Estufas estancas  
Raumluftunabhängige-Öfen  
Airtight stoves



**Like80**  
7,5 kW  
pag 12-17



**Tweed90+**  
9 kW  
pag 18-23



**Spy110+**  
10,5 kW  
pag 24-29



**Yung130++**  
12,5 kW  
pag 30-33



**Zone80**  
7,5 kW  
pag 34-37



**Berry90+**  
9 kW  
pag 38-41



**Metro110+**  
10,5 kW  
pag 42-45



**Daily130++**  
12,5 kW  
pag 46-49



**Gotha80**  
7,5 kW  
pag 50-53



**Cell90+**  
9 kW  
pag 54-57



**Entity110+**  
10,5 kW  
pag 58-61



**Dub130++**  
12,5 kW  
pag 62-65



## Stufe

Poêles  
Estufas  
Öfen  
Stoves



**Maison80**  
**Maison80+**  
8,2 kW  
8 kW  
pag 66-67



**Monday150++**  
14,8 kW  
pag 68-69



## Inserti

Inserts  
Insertables  
Einsätze  
Inserts



**Pellek80**  
**Pellek110+**  
8,3 kW  
10,5 kW  
pag 70-71



## Stufe

Poêles  
Estufas  
Öfen  
Stoves



**Decor**  
7,2 kW  
pag 80-81



**Decor C**  
7,2 kW  
pag 82-83



**Fancy**  
9 kW  
pag 84-85



## Termostufe

Thermopoêles  
Termoestufas  
Heizöfen  
Thermo stoves



**Spot100 H**  
10,1 kW  
pag 72-73



**Dore160 H**  
16,2 kW  
pag 74-75



**Monday190 H**  
**Monday230 H**  
19,2 kW  
22,8 kW  
pag 76-77



## Caldaie

Chaudières  
Calderas  
Heizkessel  
Burning boilers



**Kappa200**  
20,1 kW  
pag 78-79



**Kappa240**  
24 kW  
pag 78-79



**Kappa270**  
27 kW  
pag 78-79



## Focolari

Cheminées  
Chimeneas  
Kaminein-  
sätze  
Fireplaces



**Firek 1**  
15,2 kW  
pag 86-89



**Firek 2**  
15,2 kW  
pag 86-89



**Firek 3**  
15,2 kW  
pag 86-89

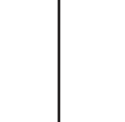
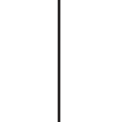
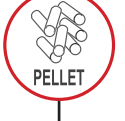
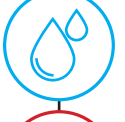
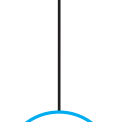
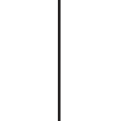
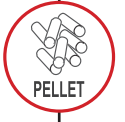
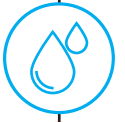

**LIKE80**





Ceramica tortora / Céramique tourterelle / Cerámica tortora / Keramik Taubengrau / Dove grey ceramic

# LIKE80



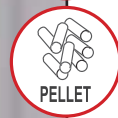

Acciaio nero opaco / Acier noire opaque / Acero negro mate / Stahl Mattschwarz/ Opaque black steel



# LIKE80

## \* IT

- Focolare in vermiculite
- Uscita fumi Ø 8 cm, superiore (versioni in ceramica e in acciaio)
- Uscita fumi: Ø 8 cm posteriore (versioni in acciaio nero opaco e bianco perla), Ø 8/13 cm coassiale (Kit optional)
- Ventilazione aria calda superiore
- Programmazione giornaliera/settimanale
- Funzione Easy Timer / Relax
- Sistema Smart con Wi-Fi integrato

## \* FR

- Foyer en vermiculite
- Sortie des fumées Ø 8 cm, vers le haut (version en céramique et acier)
- Sortie des fumées Ø 8 cm à l'arrière (version en acier noir opaque et blanc perle), coaxiale Ø 8/13 cm (Kit en option)
- Ventilation air chaud vers le haut
- Programmation journalière/hebdomadaire
- Fonction Easy Timer / Relax
- Système Smart avec Wi-fi intégré

## \* ES

- Hogar de vermiculita
- Salida humos Ø 8 cm, superior (cerámica y acero)
- Salida humos Ø 8 cm posterior (acero negro mate y blanco perla), Ø 8/13 cm coaxial (Kit opcional)
- Ventilación aire caliente superior
- Programación diaria / semanal
- Función Easy Timer / Relax
- Sistema Smart con Wi-Fi integrado

## \* DE

- Feuerraum aus vermiculite
- Rauchauslass: Ø 8 cm, oben (keramik und Stahl)
- Rauchauslass: Ø 8 cm hinten (Stahl matt schwarz und Perlweißem) Ø 8/13 cm parallelen (Kit optional)
- Warmluftgebläse oben
- Tages-/Wochen-Zeitprogrammierung
- Funktion Easy Timer / Relax
- System Smart mit integriertem WLAN

## \* EN

- Vermiculite combustion chamber
- Smoke outlet upper Ø 8 cm (ceramic and Steel)
- Smoke outlet rear Ø 8 cm (Opaque black steel and pearl white), smoke outlet Ø 8/13 cm coaxial (Kit optional)
- Hot air ventilation upper
- Daily/weekly program
- Easy Timer / Relax function
- Smart system with built-in WI-FI

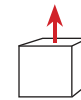

ceramica  
céramique  
cerámica  
keramik  
ceramic

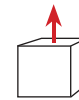

acciaio  
acier  
acero  
stahl  
steel

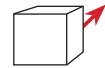

acciaio  
acier  
acero  
stahl  
steel

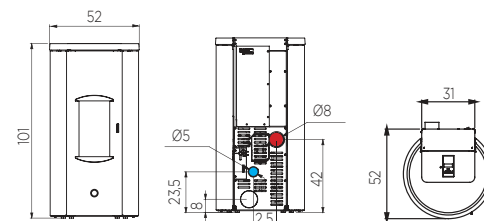
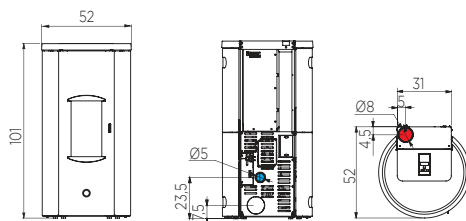

3,7-7,5



195



52x52x101h





Ceramica bianco opaco / Céramique blanc opaque / Cerámica blanco mat / Keramik Mattweiß / Matt white ceramic

# TWEED90+





Vetro nero / Verre noire / Cristal negro / Glas Schwarz / Black glass

# TWEED90+





Acciaio bordeaux / Acier bordeaux / Acero bordeaux / Stahl Bordeaux / Bordeaux steel

# TWEED90+

## \* IT

- Focolare in vermiculite
- Uscita fumi Ø 8 cm, superiore (versioni in acciaio e in vetro)
- Uscita fumi: Ø 8 cm posteriore (acciaio nero opaco e vetro bianco), Ø 8/13 cm coassiale (Kit optional)
- Ventilazione aria calda frontale
- 1 uscita aria calda canalizzabile Ø 8 cm
- Programmazione giornaliera/settimanale
- Funzione Easy Timer / Relax
- Sistema Smart con Wi-Fi integrato

## \* FR

- Foyer en vermiculite
- Sortie des fumées Ø 8 cm, vers le haut (acier et verre)
- sortie des fumées Ø 8 cm à l'arrière (acier noir opaque et verre blanc), coaxiale Ø 8/13 cm (Kit en option)
- Ventilation air chaud vers le front
- 1 sortie d'air chaud canalisable Ø 8 cm
- Programmation journalière/hebdomadaire
- Fonction Easy Timer / Relax
- Système Smart avec Wi-fi intégré

## \* ES

- Hogar de vermiculita
- Salida humos Ø 8 cm, superior (acero y cristal)
- Salida humos Ø 8 cm, posterior (acero negro mate y cristal blanco), Ø 8/13 cm coaxial (Kit opcional)
- Ventilación aire caliente frontal
- Canalización aire caliente mediante 1 salida Ø 8 cm
- Programación diaria / semanal
- Función Easy Timer / Relax
- Sistema Smart con Wi-Fi integrado

## \* DE

- Feuerraum aus vermiculite
- Rauchauslass: Ø 8 cm oben (Stahl und Glas)
- Rauchauslass: Ø 8 cm hinten (Stahl Matt schwarzer und glas weißem), Rauchauslass Ø 8/13 cm parallelen (Kit optional)
- Frontal-Warmluftgebläse
- 1 kanalzierbarer Ausgang Ø 8 cm
- Tages-/Wochen-Zeitprogrammierung
- Funktion Easy Timer / Relax
- System Smart mit integriertem WLAN

## \* EN

- Vermiculite combustion chamber
- Smoke outlet upper Ø 8 cm (steel and glass)
- Smoke outlet rear Ø 8 cm (matt black steel and white glass), smoke outlet Ø 8/13 cm coaxial (Kit optional)
- Front hot air ventilation
- 1 rear hot-air duct outlet Ø 8 cm
- Daily/weekly program
- Easy Timer/ Relax function
- Smart system with built-in WI-FI

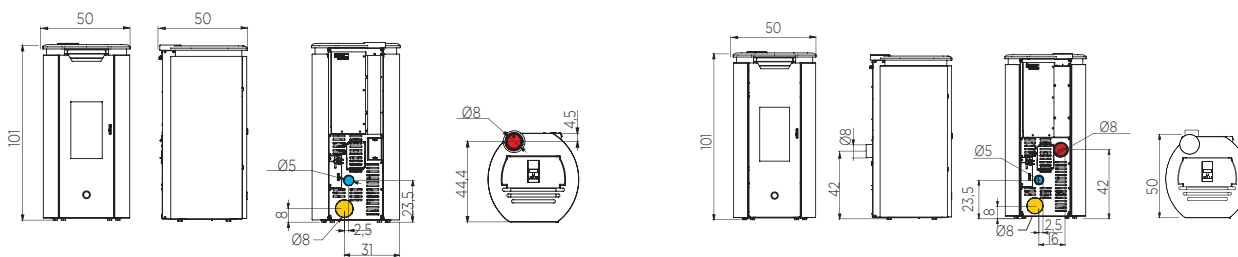
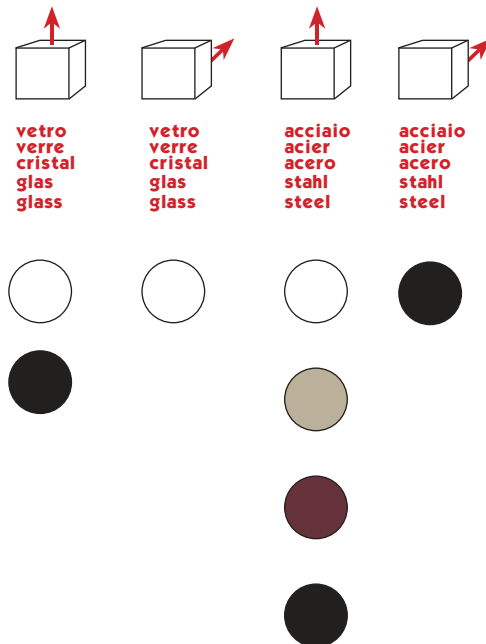

3,7-9



235



50x50x101h





Acciaio nero opaco / Acier noire opaque / Acero negro mate / Stahl Mattschwarz/ Opaque black steel



# SPY110+





Vetro bianco / Verre blanc / Cristal blanco / Glas Mattweiß / White glass

# SPY110+



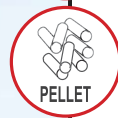
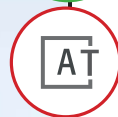

Acciaio tortora / Acier tourterelle / Acero tortora  
Stahl Taubengrau / Dove gray steel

# SPY110+

## \* IT

- Focolare in vermiculite
- Uscita fumi: Ø 8 cm posteriore, Ø 8/13 cm coassiale (Kit optional)
- Doppia porta interna in ghisa ed esterna in **vetro "Magic"**
- Ventilazione aria calda frontale
- 1 uscita aria calda canalizzabile Ø 8 cm
- Programmazione giornaliera/settimanale
- Funzione Easy Timer/ Relax
- Sistema Smart con Wi-Fi integrato

## \* FR

- Foyer en vermiculite
- Sortie des fumées Ø 8 cm à l'arrière coaxiale Ø 8/13 cm (Kit en option)
- Double porte intérieur en fonte et extérieur en **verre « Magic »**
- Ventilation air chaud vers le front
- 1 sortie d'air chaud canalisable Ø 8 cm
- Programmation journalière/hebdomadaire
- Fonction Easy Timer / Relax
- Système Smart avec Wi-fi intégré

## \* ES

- Hogar de vermiculita
- Salida humos Ø 8 cm posterior, Ø 8/13 cm coaxial (Kit opcional)
- Doble puerta interna en fundición y externa en **crystal "Magic"**
- Ventilación aire caliente frontal
- Canalización aire caliente mediante 1 salida Ø 8 cm
- Programación diaria / semanal
- Función Easy Timer / Relax
- Sistema Smart con Wi-Fi integrado

## \* DE

- Feuerraum aus vermiculite
- Rauchauslass: Ø 8 cm hinten, Ø 8/13 cm parallelen (Kit optional)
- Doppelter Tür Innentür aus Gusseisen und Außentür aus **"Magic"-Glas**
- Frontal-Warmluftgebläse
- 1 kanalisierbarer Ausgang Ø 8 cm
- Tages-/Wochen-Zeitprogrammierung
- Funktion Easy Timer / Relax
- System Smart mit integriertem WLAN

## \* EN

- Vermiculite combustion chamber
- Smoke outlet rear Ø 8 cm, smoke outlet Ø 8/13 cm coaxial (Kit optional)
- Double door: cast iron interior and **"Magic" glass** exterior
- Front hot air ventilation
- 1 hot-air duct outlet Ø 8 cm
- Daily/weekly program
- Easy Timer / Relax function
- Smart system with built-in WI-FI



vetro  
verre  
cristal  
glas  
glass

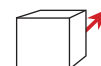

acciaio  
acier  
acero  
stahl  
steel

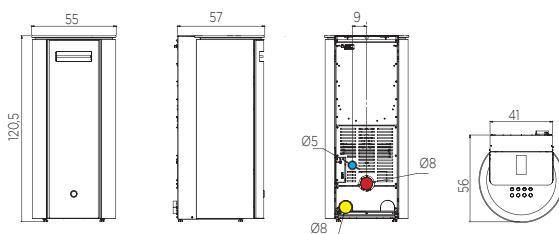

4,5-10,5



275



55x57x120,5h





Vetro nero / Verre noire / Cristal negro / Glas Schwarz / Black glass

# YUNG130++





Ceramica bianco opaco / Céramique blanc opaque / Cerámica blanco mate  
Keramik Mattweiß / Matt White ceramic



# YUNG130++

## \* IT

- Focolare in vermiculite
- Uscita fumi: Ø 8 cm posteriore, Ø 8/13 cm coassiale (Kit optional)
- Ventilazione aria calda frontale
- 2 uscite aria calda canalizzabile Ø 8 cm
- Programmazione giornaliera/settimanale
- Funzione Easy Timer / Relax
- Sistema Smart con Wi-Fi integrato

## \* FR

- Foyer en vermiculite
- Sortie des fumées Ø 8 cm à l'arrière coaxiale Ø 8/13 cm (Kit en option)
- Ventilation air chaud vers le front
- 2 sorties d'air chaud canalisables Ø 8 cm
- Programmation journalière/hebdomadaire
- Fonction Easy Timer / Relax
- Système Smart avec Wi-fi intégré

## \* ES

- Hogar de vermiculita
- Salida humos Ø 8 cm posterior, Ø 8/13 cm coaxial (Kit opcional)
- Ventilación aire caliente frontal
- Canalización aire caliente mediante 2 salidas Ø 8 cm
- Programación diaria / semanal
- Función Easy Timer / Relax
- Sistema Smart con Wi-Fi integrado

## \* DE

- Feuerraum aus vermiculite
- Rauchauslass: Ø 8 cm hinten, Ø 8/13 cm parallelen (Kit optional)
- Frontal-Warmluftgebläse
- 2 kanalisierbare Ausgänge Ø 8 cm
- Tages-/Wochen-Zeitprogrammierung
- Funktion Easy Timer / Relax
- System Smart mit integriertem WLAN

## \* EN

- Vermiculite combustion chamber
- Smoke outlet rear Ø 8 cm, Ø 8/13 cm coaxial (Kit optional)
- Front hot air ventilation
- 2 hot-air duct outlet Ø 8 cm
- Daily/weekly program
- Easy Timer / Relax function
- Smart system with built-in WI-FI



ceramica  
céramique  
cerámica  
keramik  
ceramic

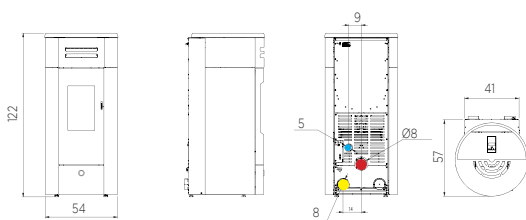

4,5-12,5



325



54x57x122h





Ceramica tortora / Céramique tourterelle / Cerámica tortora / Keramik Taubengrau / Dove grey ceramic

# ZONE80

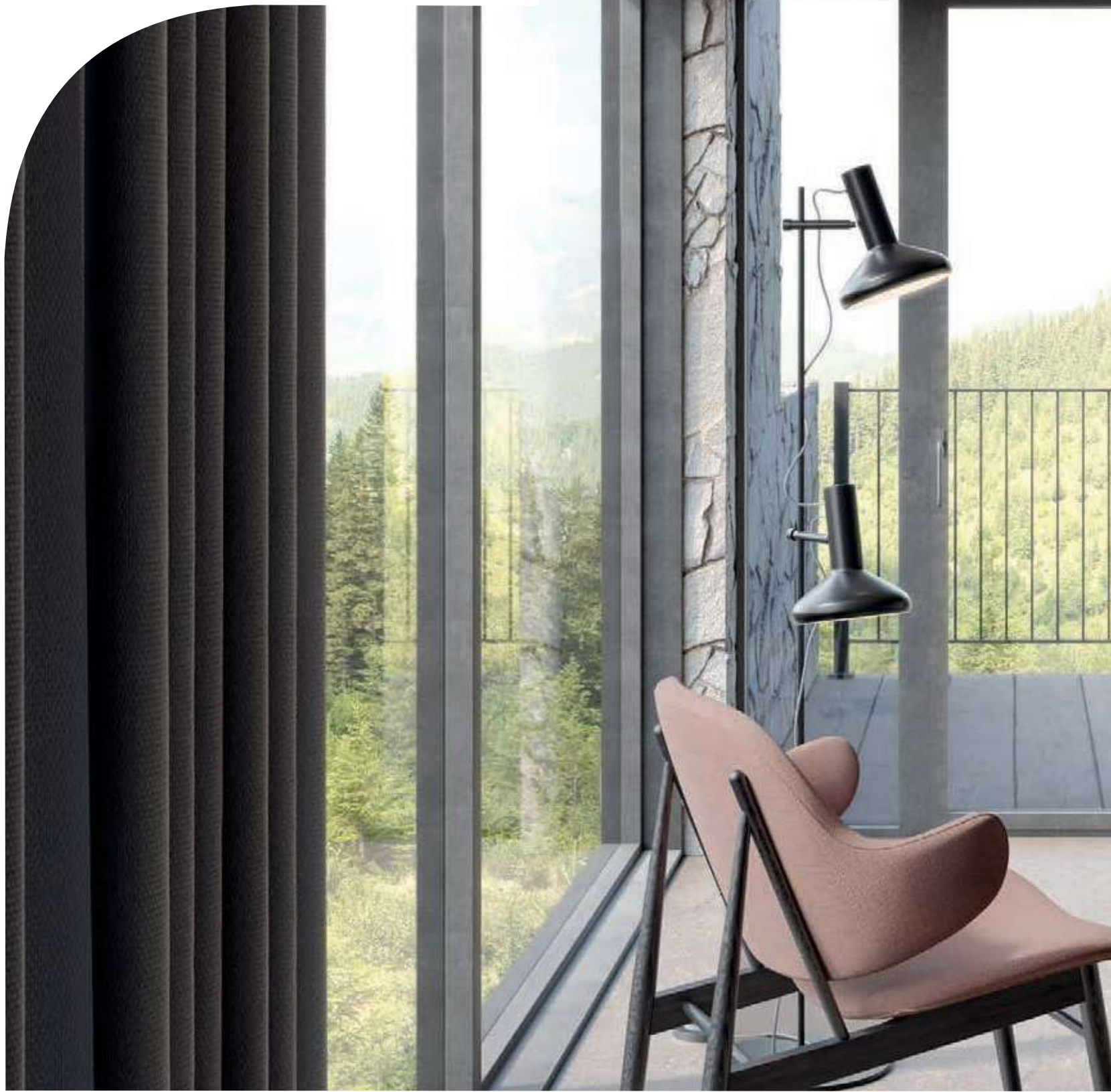



Acciaio nero opaco / Acier noire opaque / Acero negro mate  
Stahl Mattschwarz/ Matt black steel

# ZONE80

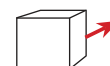

acciaio  
acier  
acero  
stahl  
steel

## \* IT

- Focolare in vermiculite
- Uscita fumi: Ø 8 cm posteriore, Ø 8/13 cm coassiale (Kit optional)
- Ventilazione aria calda superiore
- Programmazione giornaliera/settimanale
- Funzione Easy Timer / Relax
- Sistema Smart con Wi-Fi integrato

## \* FR

- Foyer en vermiculite
- Sortie des fumées Ø 8 cm à l'arrière coaxiale Ø 8/13 cm (Kit en option)
- Ventilation air chaud vers le haut
- Programmation journalière/hebdomadaire
- Fonction Easy Timer / Relax
- Système Smart avec Wi-fi intégré

## \* ES

- Hogar de vermiculita
- Salida humos Ø 8 cm posterior, Ø 8/13 cm coaxial (Kit opcional)
- Ventilación aire caliente superior
- Programación diaria / semanal
- Función Easy Timer/ Relax
- Sistema Smart con Wi-Fi integrado

## \* DE

- Feuerraum aus vermiculite
- Rauchauslass: Ø 8 cm hinten, Ø 8/13 cm parallelen (Kit optional)
- Warmluftgebläse oben
- Tages-/Wochen-Zeitprogrammierung
- Funktion Easy Timer/ Relax
- System Smart mit integriertem WLAN

## \* EN

- Vermiculite combustion chamber
- Smoke outlet rear Ø 8 cm, Smoke outlet Ø 8/13 cm coaxial (Kit optional)
- Hot air ventilation upper
- Daily/weekly program
- Easy Timer / Relax function
- Smart system with built-in WI-FI

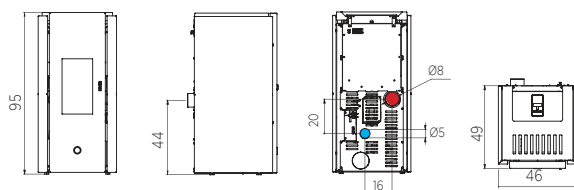

3,7-7,5



195



46x49x95h



E-SMART





Acciaio bordeaux / Acier bordeaux / Acero bordeaux / Stahl Bordeaux / Bordeaux steel



Ceramica bianco opaco / Céramique blanc opaque / Cerámica blanco mate  
Keramik Mattweiß / Matt white ceramic



# BERRY90+





Ceramica tortora / Céramique tourterelle / Cerámica tortora / Keramik Taubengrau / Dove grey ceramic

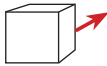

ceramica  
céramique  
cerámica  
keramik  
ceramic



## BERRY90+

### \* IT

- Focolare in vermiculite
- Uscita fumi: Ø 8 cm posteriore, Ø 8/13 cm coassiale (Kit optional)
- Ventilazione aria calda frontale
- 1 uscita aria calda canalizzabile Ø 8 cm
- Programmazione giornaliera/settimanale
- Funzione Easy Timer / Relax
- Sistema Smart con Wi-Fi integrato

### \* FR

- Foyer en vermiculite
- Sortie des fumées Ø 8 cm à l'arrière coaxiale Ø 8/13 cm (Kit en option)
- Ventilation air chaud vers le front
- 1 sortie d'air chaud canalisable, Ø 8 cm
- Programmation journalière/hebdomadaire
- Fonction Easy Timer / Relax
- Système Smart avec Wi-fi intégré

### \* ES

- Hogar de vermiculita
- Salida humos Ø 8 cm posterior, Ø 8/13 cm coaxial (Kit opcional)
- Ventilación aire caliente frontal
- Canalización aire caliente mediante 1 salida Ø 8 cm
- Programación diaria / semanal
- Función Easy Timer / Relax
- Sistema Smart con Wi-Fi integrado

### \* DE

- Feuerraum aus vermiculite
- Rauchauslass: Ø 8 cm hinten, Ø 8/13 cm parallelen (Kit optional)
- Frontal-Warmluftgebläse
- 1 kanalisierbarer Ausgang Ø 8
- Tages-/Wochen-Zeitprogrammierung
- Funktion Easy Timer / Relax
- System Smart mit integriertem WLAN

### \* EN

- Vermiculite combustion chamber
- Smoke outlet rear Ø 8 cm, smoke outlet Ø 8/13 cm coaxial (Kit optional)
- Front hot air ventilation
- 1 hot-air duct outlet Ø 8 cm
- Daily/weekly program
- Easy Timer / Relax function
- Smart system with built-in WI-FI

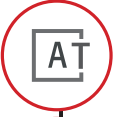
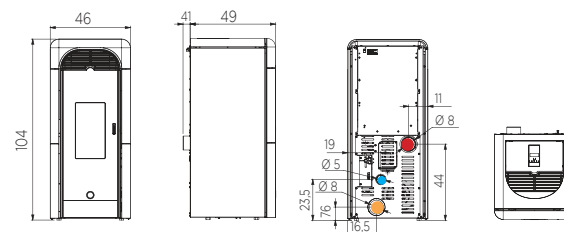

\*Dati di progetto / Données de projet / Datos de proyecto / Projekttaten / Project data



3,7-9



235



46x49x104h



E-SMART



# METRO110+





Acciaio nero opaco / Acier noire opaque / Acero negro mate / Stahl Mattschwarz / Matt black steel

# METRO110+

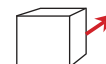

acciaio  
acier  
acero  
stahl  
steel

## \* IT

- Focolare in vermiculite
- Uscita fumi: Ø 8 cm posteriore, Ø 8/13 cm coassiale (Kit optional)
- Ventilazione aria calda frontale
- 1 uscita aria calda canalizzabile Ø 8 cm
- Programmazione giornaliera/settimanale
- Funzione Easy Timer / Relax
- Sistema Smart con Wi-Fi integrato

## \* FR

- Foyer en vermiculite
- Sortie des fumées Ø 8 cm à l'arrière coaxiale Ø 8/13 cm (Kit en option)
- Ventilation air chaud vers le front
- 1 sortie d'air chaud canalisable, Ø 8 cm
- Programmation journalière/hebdomadaire
- Fonction Easy Timer / Relax
- Système Smart avec Wi-fi intégré

## \* ES

- Hogar de vermiculita
- Salida humos Ø 8 cm posterior, Ø 8/13 cm coaxial (Kit opcional)
- Ventilación aire caliente frontal
- Canalización aire caliente mediante 1 salida Ø 8 cm
- Programación diaria / semanal
- Función Easy Timer / Relax
- Sistema Smart con Wi-Fi integrado

## \* DE

- Feuerraum aus vermiculite
- Rauchauslass: Ø 8 cm hinten, Ø 8/13 cm parallelen (Kit optional)
- Frontal-Warmluftgebläse
- 1 kanalisierbarer Ausgang Ø 8 cm
- Tages-/Wochen-Zeitprogrammierung
- Funktion Easy Timer / Relax
- System Smart mit integriertem WLAN

## \* EN

- Vermiculite combustion chamber
- Smoke outlet rear Ø 8 cm, Smoke outlet Ø 8/13 cm coaxial (Kit optional)
- Front hot air ventilation
- 1 hot-air duct outlet Ø 8 cm
- Daily/weekly program
- Easy Timer / Relax function
- Smart system with built-in WI-FI

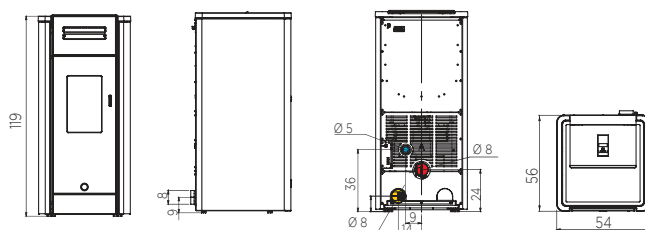

4,5-10,5



275



54x56x119h



E-SMART



CSTB



ECO1



CONTO TERMICO



WIFI



Acciaio bianco perla / Acier blanc perl / Acero perla blanco  
Stahl Perlweiß / Pearl white steel



Ceramica tortora / Céramique tourterelle / Cerámica tortora / Keramik Taubengrau / Dove grey ceramic



# DAILY130++





Ceramica bordeaux / Céramique bordeaux / Cerámica bordeaux / Keramik bordeaux / Bordeaux ceramic



ceramica  
céramique  
cerâmica  
keramik  
ceramic



## DAILY130++

### \* IT

- Focolare in vermiculite
- Uscita fumi: Ø 8 cm posteriore, Ø 8/13 cm coassiale (Kit optional)
- Ventilazione aria calda frontale
- 2 uscite aria calda canalizzabile Ø 8 cm
- Programmazione giornaliera/settimanale
- Funzione Easy Timer/ Relax
- Sistema Smart con Wi-Fi integrato

### \* FR

- Foyer en vermiculite
- Sortie des fumées Ø 8 cm à l'arrière coaxiale Ø 8/13 cm (Kit en option)
- Ventilation air chaud vers le front
- 2 sorties d'air chaud canalisables Ø 8 cm
- Programmation journalière/hebdomadaire
- Fonction Easy Timer / Relax
- Système Smart avec Wi-fi intégré

### \* ES

- Hogar de vermiculita
- Salida humos Ø 8 cm posterior, Ø 8/13 cm coaxial (Kit opcional)
- Ventilación aire caliente frontal
- Canalización aire caliente mediante 2 salidas Ø 8 cm
- Programación diaria / semanal
- Función Easy Timer/ Relax
- Sistema Smart con Wi-Fi integrado

### \* DE

- Feuerraum aus vermiculite
- Rauchauslass: Ø 8 cm hinten, Ø 8/13 cm parallelen (Kit optional)
- Frontal-Warmluftgebläse
- 2 kanalisierbare Ausgänge Ø 8 cm
- Tages-/Wochen-Zeitprogrammierung
- Funktion Easy Timer/ Relax
- System Smart mit integriertem WLAN

### \* EN

- Vermiculite combustion chamber
- Smoke outlet rear Ø 8 cm, smoke outlet upper Ø 8/13 cm coaxial (Kit optional)
- Front hot air ventilation
- 2 hot-air duct outlet Ø 8 cm
- Daily/weekly program
- Easy Timer / Relax function
- Smart system with built-in WI-FI

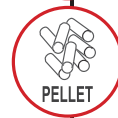
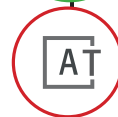
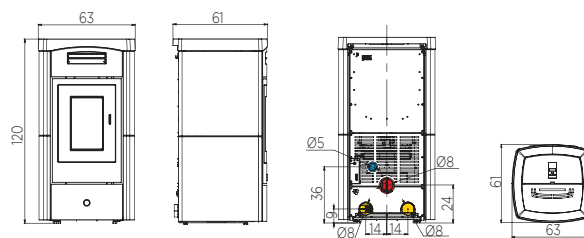

\*Dati di progetto / Données de projet / Datos de proyecto / Projekttaten / Project data



4,5-12,5



325



63x61x120h



E-SMART





Acciaio bianco perla / Acier blanc perl / Acero perla blanco / Stahl Perlweiß / Pearl white steel



# GOTHA80



Acciaio bordeaux / Acier bordeaux / Acero bordeaux  
Stahl Bordeaux / Bordeaux steel



acciaio  
acier  
acero  
stahl  
steel



# GOTHA80

## \* IT

- Focolare in vermiculite
- Uscita fumi Ø 8 cm superiore
- Ventilazione aria calda superiore
- Programmazione giornaliera/settimanale
- Funzione Easy Timer / Relax
- Sistema Smart con Wi-Fi integrato

## \* FR

- Foyer en vermiculite
- Sortie des fumées Ø 8 cm vers le haut
- Ventilation air chaud vers le haut
- Programmation journalière/hebdomadaire
- Fonction Easy Timer / Relax
- Système Smart avec Wi-fi intégré

## \* ES

- Hogar de vermiculita
- Salida humos Ø 8 cm superior
- Ventilación aire caliente superior
- Programación diaria / semanal
- Función Easy Timer / Relax
- Sistema Smart con Wi-Fi integrado

## \* DE

- Feuerraum aus vermiculite
- Rauchauslass: Ø 8 cm oben
- Warmluftgebläse oben
- Tages-/Wochen-Zeitprogrammierung
- Funktion Easy Timer / Relax
- System Smart mit integriertem WLAN

## \* EN

- Vermiculite combustion chamber
- Smoke outlet upper Ø 8 cm
- Hot air ventilation upper
- Daily/weekly program
- Easy Timer / Relax function
- Smart system with built-in WI-FI

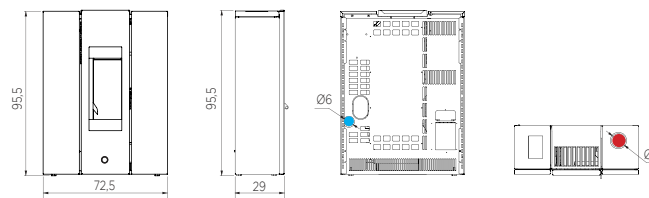

3,7-7,5



195



72,5x29x95,5h



\*Dati di progetto / Données de projet / Datos de proyecto / Projekttaten / Project data

# CELL90+





Acciaio bianco perla / Acier blanc perl / Acero perla blanco  
Stahl Perlweiß / Pearl white steel



# CELL90+

## \* IT

- Focolare in vermiculite
- Uscita fumi: Ø 8 cm superiore, Ø 8/13 cm superiore coassiale, versioni in acciaio nero opaco e bianco perla
- Ventilazione aria calda frontale
- 1 uscita aria calda canalizzabile Ø 8 cm
- Programmazione giornaliera/settimanale
- Funzione Easy Timer / Relax
- Sistema Smart con Wi-Fi integrato

## \* FR

- Foyer en vermiculite
- Sortie des fumées Ø 8 cm vers le haut, coaxiale Ø 8/13 cm vers le haut, versions en acier noir mat et blanc perle
- Ventilation air chaud vers le front
- 1 sortie d'air chaud canalisable Ø 8 cm
- Programmation journalière/hebdomadaire
- Fonction Easy Timer / Relax
- Système Smart avec Wi-fi intégré

## \* ES

- Hogar de vermiculita
- Salida humos Ø 8 cm superior, salida de humos superior Ø 8/13 cm coaxial, acero negro mate y perla blanco
- Ventilación aire caliente frontal
- Canalización aire caliente mediante 1 salida Ø 8 cm
- Programación diaria / semanal
- Función Easy Timer / Relax
- Sistema Smart con Wi-Fi integrado

## \* DE

- Feuerraum aus vermiculite
- Rauchauslass: Ø 8 cm oben, oben Ø 8/13 cm parallelen, Versionen mit mattschwarzem und perlweißem Stahl
- Frontal-Warmluftgebläse
- 1 kanalisierbarer Ausgang Ø 8 cm
- Tages-/Wochen-Zeitprogrammierung
- Funktion Easy Timer / Relax
- System Smart mit integriertem WLAN

## \* EN

- Vermiculite combustion chamber
- Smoke outlet upper Ø 8 cm, Smoke outlet upper Ø 8/13 cm coaxial, versions in steel in matt black and pearl white
- Front hot air ventilation
- 1 hot-air duct outlet Ø 8 cm
- Daily/weekly program
- Easy Timer / Relax function
- Smart system with built-in WI-FI

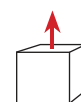

acciaio  
acier  
acero  
stahl  
steel

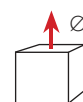

Ø 8/13

acciaio  
acier  
acero  
stahl  
steel

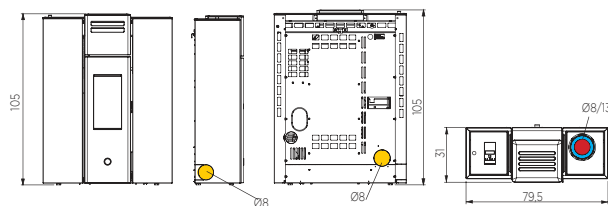
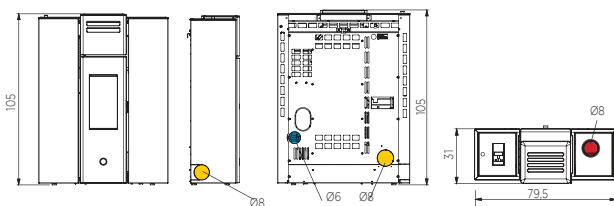

3,7-9



235



79,5x31x105h





Acciaio nero opaco / Acier noire opaque / Acero negro mate / Stahl Mattschwarz / Matt black steel



Acciaio tortora / Acier tourterelle / Acero tortora / Stahl Taubengrau / Dove grey steel



**ENTITY110+**



Acciaio bianco perla / Acier blanc perl / Acero perla blanco / Stahl Perlweiß / Pearl white steel

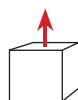

acciaio  
acier  
acero  
stahl  
steel

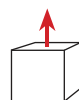

Ø 8/13

acciaio  
acier  
acero  
stahl  
steel



## ENTITY110+

### \* IT

- Focolare in vermiculite
- Uscita fumi: Ø 8 cm superiore  
Ø 8/13 cm superiore coassiale versioni in acciaio nero opaco e bianco perla
- Ventilazione aria calda frontale
- 1 uscita aria calda canalizzabile Ø 8 cm
- Programmazione giornaliera/settimanale
- Funzione Easy Timer / Relax
- Sistema Smart con Wi-Fi integrato

### \* FR

- Foyer en vermiculite
- Sortie des fumées Ø 8 cm vers le haut  
coaxiale Ø 8/13 cm vers le haut versions en acier noir mat et blanc perle
- Ventilation air chaud vers le front
- 1 sortie d'air chaud canalisable Ø 8 cm
- Programmation journalière/hebdomadaire
- Fonction Easy Timer / Relax
- Système Smart avec Wi-fi intégré

### \* ES

- Hogar de vermiculita
- Salida humos Ø 8 cm superior,  
salida de humos superior Ø 8/13 cm coaxial versione acero negro mate y blanco perla
- Ventilación aire caliente frontal
- Canalización aire caliente mediante 1 salida Ø 8 cm
- Programación diaria / semanal
- Función Easy Timer / Relax
- Sistema Smart con Wi-Fi integrado

### \* DE

- Feuerraum aus vermiculite
- Rauchauslass: Ø 8 cm oben,  
oben Ø 8/13 cm parallelen, versionen mit mattschwarzem und perlweißem Stahl
- Frontal-Warmluftgebläse
- 1 kanalisierbarer Ausgang Ø 8 cm
- Tages-/Wochen-Zeitprogrammierung
- Funktion Easy Timer / Relax
- System Smart mit integriertem WLAN

### \* EN

- Vermiculite combustion chamber
- Smoke outlet upper Ø 8 cm,  
Smoke outlet upper Ø 8/13 cm coaxial versions in steel in matt black and pearl white
- Front hot air ventilation
- 1 hot-air duct outlet Ø 8 cm
- Daily/weekly program
- Easy Timer / Relax function
- Smart system with built-in WI-FI

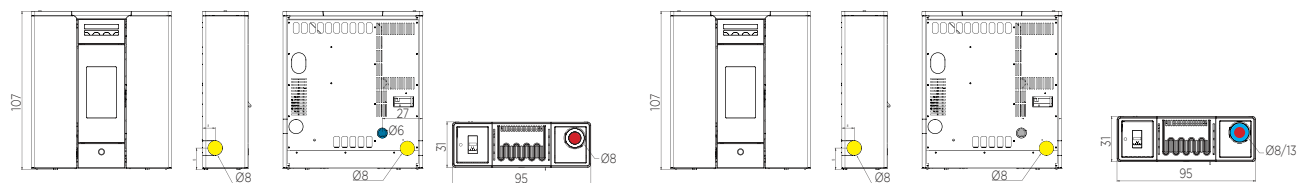

4,5-10,5



275



95x31x107h



**DUB130++**





Ceramica nero opaco / Céramique noire opaque / Cerámica negro mate  
Keramik Mattschwarz / Matt black ceramic



# DUB130++

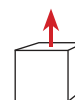

ceramica  
céramique  
cerâmica  
keramik  
ceramic

## \* IT

- Focolare in vermiculite
- Uscita fumi: Ø 8 cm superiore
- Ventilazione aria calda frontale
- 2 uscite aria calda canalizzabili Ø 8 cm
- Programmazione giornaliera/settimanale
- Funzione Easy Timer / Relax
- Sistema Smart con Wi-Fi integrato

## \* FR

- Foyer en vermiculite
- Sortie des fumées Ø 8 cm vers le haut
- Ventilation air chaud vers le front
- 2 sorties d'air chaud canalisable Ø 8 cm
- Programmation journalière/hebdomadaire
- Fonction Easy Timer / Relax
- Système Smart avec Wi-fi intégré

## \* ES

- Hogar de vermiculita
- Salida humos Ø 8 cm superior
- Ventilación aire caliente frontal
- Canalización aire caliente mediante 2 salidas Ø 8 cm
- Programación diaria / semanal
- Función Easy Timer / Relax
- Sistema Smart con Wi-Fi integrado

## \* DE

- Feuerraum aus vermiculite
- Rauchauslass: Ø 8 cm oben
- Frontal-Warmluftgebläse
- 2 kanalisierbare Ausgänge Ø 8 cm
- Tages-/Wochen-Zeitprogrammierung
- Funktion Easy Timer / Relax
- System Smart mit integriertem WLAN

## \* EN

- Vermiculite combustion chamber
- Smoke outlet upper Ø 8 cm
- Front hot air ventilation
- 2 rear hot-air duct outlet Ø 8 cm
- Daily/weekly program
- Easy Timer / Relax function
- Smart system with built-in WI-FI

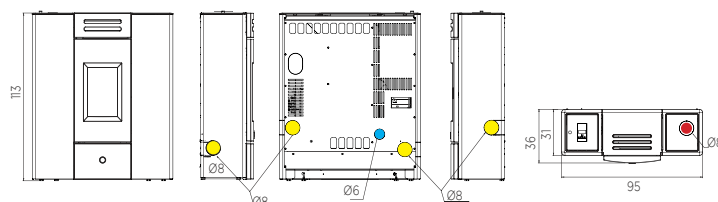

4,5-12,5



325



95x36x113h



E-SMART



CSTB  
Qual Air Network  
BY INNOVATION



ECO1  
GREEN  
2022  
OF THE  
CERTIFICATION



CONTO  
TÈRMICO  
BY INNOVATION



BY INNOVATION  
BY INNOVATION



Ceramica bianco opaco / Céramique blanc opaque / Cerámica blanco mate / Keramik Mattweiß / Matt white ceramic



Ceramica bordeaux / Céramique bordeaux / Cerámica bordeaux  
Keramik Bordeaux / Bordeaux ceramic

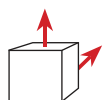

ceramica  
céramique  
cerámica  
keramik  
ceramic



# MAISON80 MAISON80+

## \* IT

- Focolare in vermiculite
- Uscita fumi: Ø 8 cm posteriore e superiore
- Canalizzazione aria calda tramite 1 uscita Ø 8 cm (**Maison80+**)
- Programmazione giornaliera/settimanale
- Funzione Easy Timer / Relax
- Sistema Smart con Wi-Fi integrato

## \* FR

- Foyer en vermiculite
- Sortie des fumées Ø 8 cm à l'arrière et vers le haut
- 1 sortie d'air chaud canalisable Ø 8 cm (**Maison80+**)
- Programmation journalière/hebdomadaire
- Fonction Easy Timer / Relax
- Système Smart avec Wi-fi intégré

## \* ES

- Hogar de vermiculita
- Salida humos Ø 8 cm posterior y superior
- Canalización aire caliente mediante 1 salida Ø 8 cm (**Maison80+**)
- Programación diaria / semanal
- Función Easy Timer / Relax
- Sistema Smart con Wi-Fi integrado

## \* DE

- Feuerraum aus vermiculite
- Rauchauslass: Ø 8 cm hinten und oben
- Kanalisierung der Warmluft 1 Auslass Ø 8 cm (**Maison80+**)
- Tages-/Wochen-Zeitprogrammierung
- Funktion Easy Timer / Relax
- System Smart mit integriertem WLAN

## \* EN

- Vermiculite combustion chamber
- Smoke outlet rear and upper Ø 8 cm
- 1 hot-air duct outlet Ø 8 cm (**Maison80+**)
- Daily/weekly program
- Easy Timer / Relax function
- Smart system with built-in WI-FI

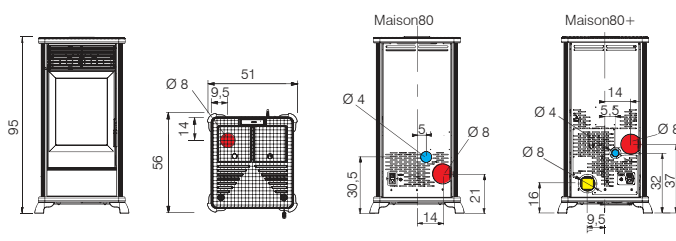

2,5-8,2  
\*2,5-8



\*215  
\*210



51x56x95h  
51x56x95h



Classe Ambientale  
DM 186

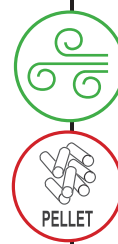

# MONDAY150++

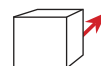

ceramica-acciaio  
céramique-acier  
cerámica-acero  
keramik-stahl  
ceramic-steel



## \* IT

- Focolare in vermiculite
- Uscita fumi: Ø 8 cm posteriore
- Ventilazione aria calda frontale
- 2 uscite aria calda canalizzabile Ø 8 cm
- Programmazione giornaliera/settimanale
- Funzione Easy Timer / Relax
- Sistema Smart con Wi-Fi integrato

## \* FR

- Foyer en vermiculite
- Sortie des fumées Ø 8 cm à l'arrière
- Ventilation frontal air chaud désactivable
- 2 sorties d'air chaud canalisables Ø 8 cm
- Programmation journalière/hebdomadaire
- Fonction Easy Timer / Relax
- Système Smart avec Wi-fi intégré

## \* ES

- Hogar de vermiculita
- Salida humos Ø 8 cm posterior
- Ventilación aire caliente frontal
- Canalización aire caliente mediante 2 salide Ø 8 cm
- Programación diaria / semanal
- Función Easy Timer/ Relax
- Sistema Smart con Wi-Fi integrado

## \* DE

- Feuerraum aus vermiculite
- Rauchauslass: Ø 8 cm hinten
- Frontal-Warmluftgebläse
- 2 kanalisierbare Ausgänge Ø 8 cm
- Tages-/Wochen-Zeitprogrammierung
- Funktion Easy Timer / Relax
- System Smart mit integriertem WLAN

## \* EN

- Vermiculite combustion chamber
- Smoke outlet rear Ø 8 cm
- 2 rear hot-air duct outlet Ø 8 cm
- Front hot air ventilation
- Daily/weekly program
- Easy Timer / Relax function
- Smart system with built-in WI-FI

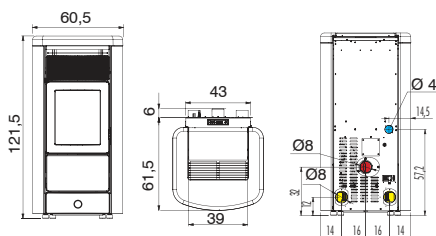

\* Dati di progetto / Données de projet / Datos de proyecto / Projektdaten / Project data



\*4,8-14,8



\*385



60,5x61,5x121,5h



Classe Ambientale  
DM 166





Acciaio-ceramica bianco opaco / Acier-c eramique blanc opaque / Acero-cer mica blanco mate  
Stahl Keramik Mattwei  / Matt White ceramic-steel





3,5-8,3  
3,5-10,5



215  
275



73,5x49x49h  
73,5x49x49h



E-SMART



Classe Ambientale  
DM 186



### Caricamento pellet a inserto SPENTO (senza optional)

Chargement à pellet à insert **ÉTEINT** (sans options)  
Carga de pellet con insertable **APAGADO** (sins opcional)  
Pellets-Befüllung mit **AUSGESCHALTETEM** Einsatz (ohne option)  
Pellet load with insert **OFF** (no optional)

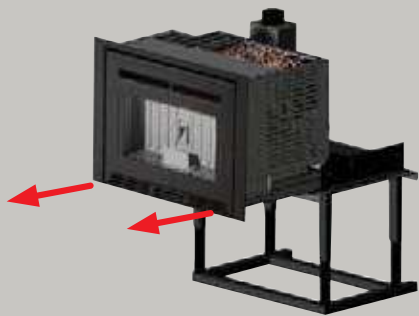

estrazione su guide | extraction sur glissières | extracción sobre guías  
extraktion auf Gleitschienen | extraction on slide rails

### Caricamento pellet a inserto ACCESO (con optional)

Chargement des pellet à insert **ALLUMÉ** (avec options)  
Carga de pellet con insertable **ENCENDIDO** (con opcional)  
Pellets-Befüllung mit **EINGESCHALTETEM** Einsatz (mit option)  
Pellet load with insert **ON** (with optional)



con cassetto | avec tiroir |  
con cajón | Über Schublade |  
Through the front loading tray



a botola | par trappe |  
por trampilla | Über Einfüllrutsche |  
Trapdoor fillin

## PELLEK80 PELLEK110+

### \* IT

- Focolare in ghisa
- Uscita fumi Ø 8 cm superiore
- Ventilazione aria calda frontale
- 1 uscita aria calda canalizzabile Ø 6 cm (**Pellek110+**)
- Programmazione giornaliera/settimanale
- Funzione Easy Timer
- Sistema Smart con Wi-Fi integrato

### \* FR

- Foyer en fonte
- Sortie des fumées Ø 8 cm vers le haut
- Ventilation air chaud vers le front
- 1 sortie d'air chaud canalisable, Ø 6 cm (**Pellek110+**)
- Programmation journalière/hebdomadaire
- Fonction Easy Timer
- Système Smart avec Wi-fi intégré

### \* ES

- Hogar de fundición
- Salida humos Ø 8 cm superior
- Ventilación aire caliente frontal
- Canalización aire caliente mediante 1 salida Ø 6 cm (**Pellek110+**)
- Programación diaria / semanal
- Función Easy Timer
- Sistema Smart con Wi-Fi integrado

### \* DE

- Feuerraum aus Gusseisen
- Rauchauslass: Ø 8 cm oben
- Frontal-Warmluftgebläse
- Kanalisierung der Warmluft über 1 Auslass Ø 6 cm (**Pellek110+**)
- Tages-/Wochen-Zeitprogrammierung
- Funktion Easy Timer
- System Smart mit integriertem WLAN

### \* EN

- Cast iron combustion chamber
- Smoke outlet upper Ø 8 cm
- Front hot air ventilation
- 1 hot-air duct outlet Ø 6 cm (**Pellek110+**)
- Daily/weekly program
- Easy Timer function
- Smart system with built-in WI-FI

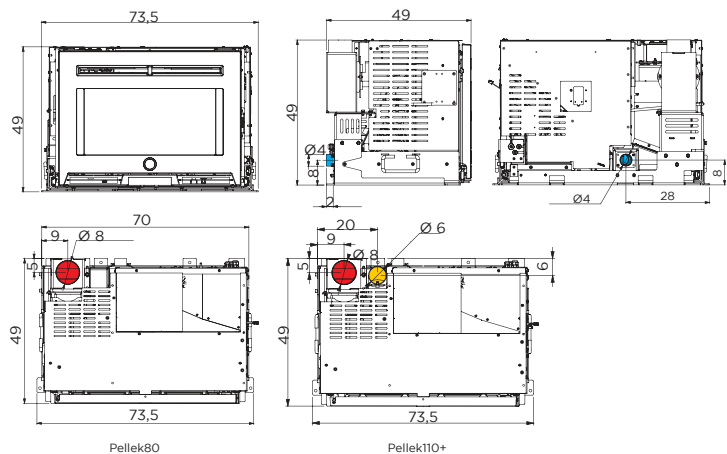



# SPOT100 H



ceramica  
céramique  
cerámica  
keramik  
ceramic



## \* IT

- Focolare in acciaio e vermiculite
- Uscita fumi Ø 8 cm posteriore (laterale sinistra e superiore con kit optional)
- Kit idraulico incorporato con vaso d'espansione chiuso, circolatore e valvola di sovrappressione
- Programmazione giornaliera/settimanale
- Telecomando Slim

## \* FR

- Foyer acier et en vermiculite
- Sortie des fumées Ø 8 cm à l'arrière (latérale gauche ou vers le haut avec kit en option)
- Kit incorporé avec vase d'expansion fermé, circulateur et groupe de sécurité
- Programmation journalière/hebdomadaire
- Télécommande Slim

## \* ES

- Hogar en acero y vermiculita
- Salida humos Ø 8 cm, posterior (lateral izquierda y superior con kit opcional)
- Kit hidráulico incorporado con vaso de expansión cerrado, circulador y válvula de sobrepresión.
- Programación diaria / semanal
- Telemando Slim

## \* DE

- Feuerraum aus Stahl und vermiculite
- Rauchrohranschluss Ø 8 cm, hinten (oben oder seitlich links kit optional)
- Integrierter Hydraulikbausatz mit geschlossenem Ausdehnungsgefäß, Umwälzpumpe und Überdruckventil
- Tages-/Wochen-Zeitprogrammierung
- Funksteuerung Slim

## \* EN

- Steel and Vermiculite combustion chamber
- Smoke outlet Ø 8 cm, rear (upper or left side whit kit optional)
- Incorporated hydraulic kit with closed expansion tank, circulator pump and pressure relief valve
- Daily/weekly program
- Remote control Slim

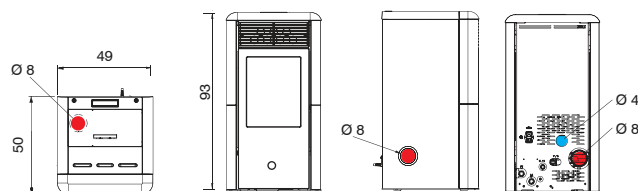

3,8-10,1



6,5



265



49x50x93h



Classe Ambientale  
DM 186



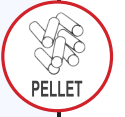
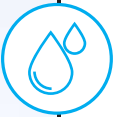

Ceramica bianco panna / Céramique blanc crème / Cerámica blanco crema  
Keramik Cremeweiß / Cream white ceramic



Acciaio-ceramica pergameña / Acier- céramique parchemin / Acero-cerámica pergamino  
Stahl-Keramik Pergamentfarben / Parchment steel-ceramic



ceramica-acciaio  
céramique-acier  
cerámica-acero  
keramik-stahl  
ceramic-steel



## DORE160 H

### \* IT

- Focolare in acciaio e ghisa
- Uscita fumi: Ø 8 cm posteriore
- Ventilazione aria calda frontale
- Kit idraulico incorporato con vaso d'espansione chiuso, circolatore e valvola di sovrappressione
- Programmazione giornaliera/settimanale

### \* FR

- Foyer en acier et fonte
- Sortie des fumées Ø 8 cm à l'arrière
- Ventilation air chaud vers le front
- Kit incorporé avec vase d'expansion fermé, circulateur et groupe de sécurité
- Programmation journalière/hebdomadaire

### \* ES

- Hogar de fundición y acero
- Salida humos Ø 8 cm posterior
- Ventilación aire caliente frontal
- Kit hidráulico incorporado con vaso de expansión cerrado, circulador y válvula de sobrepresión.
- Programación diaria / semanal

### \* DE

- Feuerraum aus Stahl und Gusseisen
- Rauchauslass: Ø 8 cm hinten
- Frontal-Warmluftgebläse
- Integrierter Hydraulikbausatz mit geschlossenem Ausdehnungsgefäß, Umwälzpumpe und Überdruckventil
- Tages-/Wochen-Zeitprogrammierung

### \* EN

- Steel and cast iron combustion chamber
- Smoke outlet rear Ø 8 cm
- Front hot air ventilation
- Incorporated hydraulic kit with closed expansion tank, circulator pump and pressure relief valve
- Daily/weekly program

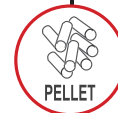
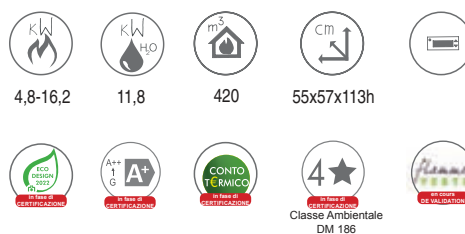
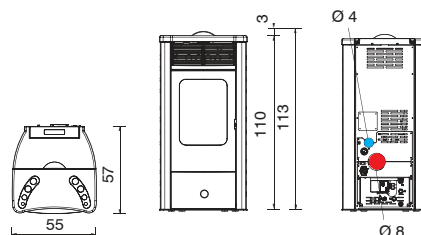

# MONDAY190 H

# MONDAY230 H



ceramica-acciaio  
céramique-acier  
cerámica-acero  
keramik-stahl  
ceramic-steel



## \* IT

- Focolare in acciaio
- Uscita fumi: Ø 8 cm posteriore
- Ventilazione aria calda frontale
- Vaso espansione chiuso
- Programmazione giornaliera/settimanale

## \* FR

- Foyer en acier
- Sortie des fumées Ø 8 cm à l'arrière
- Ventilation air chaud vers le front
- Vase d'expansion fermé incorporé
- Programmation journalière/hebdomadaire

## \* ES

- Hogar de acero
- Salida humos Ø 8 cm posterior
- Ventilación aire caliente frontal
- Vaso expansión cerrado
- Programación diaria / semanal

## \* DE

- Feuerraum aus Stahl
- Rauchauslass: Ø 8 cm hinten
- Frontal-Warmluftgebläse
- Geschlossenes Ausdehnungsgefäß inbegriffen
- Tages-/Wochen-Zeitprogrammierung

## \* EN

- Steel combustion chamber
- Smoke outlet rear Ø 8 cm
- Front hot air ventilation
- Closed expansion tank
- Daily/weekly program

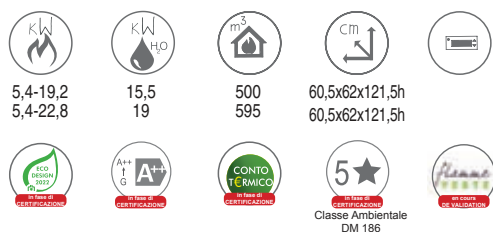
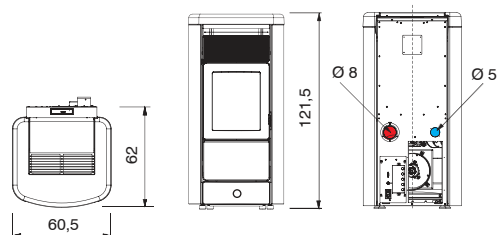



Acciaio- ceramica bordeaux / Acier -Céramique bordeaux / Acero -cerámica bordeaux  
Stahl Keramik Bordeaux / Bordeaux steel-ceramic



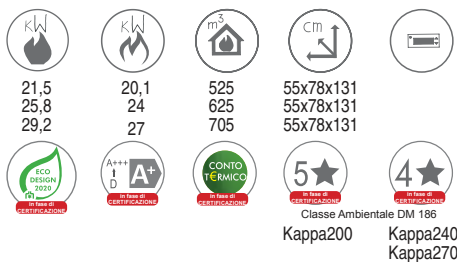

# KAPPA200 KAPPA240 KAPPA270



## \* IT

- Focolare in acciaio e ghisa
- Uscita fumi: Ø 8 cm posteriore
- Doppio portello isolato
- Vaso espansione chiuso
- Serbatoio pellet capacità 60 kg/94 L
- Programmazione giornaliera/settimanale
- Classe 5 secondo la norma EN 303-5.

## \* FR

- Foyer en acier et fonte
- Sortie des fumées Ø 8 cm à l'arrière
- Double porte isolée
- Vase d'expansion fermé incorporé
- Réservoir à granulés d'une capacité de 60 kg/94 l
- Programmation journalière/hebdomadaire
- Classe 5 selon norme EN 303-5

## \* ES

- Hogar en acero y fundición
- Salida humos Ø 8 cm posterior
- Doble puerta aislada
- Vaso de expansión cerrado
- Depósito 60 kg/94 L
- Programación diaria / semanal
- Clase 5 según las normas EN 303-5

## \* DE







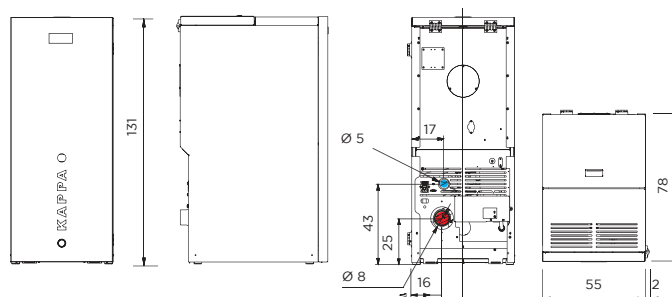







- Feuerraum aus Stahl und Gusseisen
- Rauchauslass: Ø 8 cm hinten
- Doppelt isolierte Tür
- Geschlossenes Ausdehnungsgefäß inbegriffen
- Tank 60 kg/94 L
- Tages-/Wochen-Zeitprogrammierung
- Klass 5 nach den Normen EN 303-5













## \* EN

- Steel and cast iron combustion chamber
- Smoke outlet rear Ø 8 cm
- Double insulated door
- Included closed expansion tank
- 60 kg/ 94 L tank
- Daily/weekly program
- Class 5 according to the standards: EN 303-5





	* IT	* FR	* ES	* DE	* EN
	Installazione coassiale	Installation coaxiale	Instalación coaxial	Koaxiale Installation	Coaxial installation
	<b>Air Tight</b> Stufe stagne completamente ermetiche rispetto all'ambiente di installazione	<b>Air Tight</b> Les poêles étanches sont complètement hermétiques par rapport à la pièce où ils sont installés	<b>Air Tight</b> Estufas estancas completamente herméticas respecto al ambiente de la instalación.	<b>Air Tight</b> Raumluftunabhängige Öfen, gegenüber der Installationsumgebung komplett abgedichtet	<b>Air Tight</b> Fully airtight stoves with respect to the rooms where they are installed
	<b>Passive House</b> Adatta per le moderne case passive	<b>Passive House</b> Idéal pour les maisons passives modernes	<b>Passive House</b> Apta para las modernas casas pasivas.	<b>Passive House</b> Geeignet für moderne Passivhäuser	<b>Passive House</b> Suitable for modern passive houses
	<b>Autocheck a freddo</b> Permette di individuare eventuali inconvenienti	<b>Autocheck a froid</b> Permet d'identifier des inconvénients éventuels	<b>Autocheck</b> Permite individuar eventuales inconvenientes.	<b>Autocheck</b> Automatischer Reinigung des Brenntiegels	<b>Cold Autocheck</b> Allows identification of any problems
	<b>Autoclean</b> Pulizia automatica del crogiolo	<b>Autoclean</b> Nettoyage automatique du creuset	<b>Autoclean</b> Limpieza automática del crisol	<b>Autoclean</b> Automatische Reinigung der Brennerschale	<b>Autoclean</b> Automatic cleaning of the burning pot
	<b>****Canalizzazione</b>	<b>****Canalisation</b>	<b>****Canalización</b>	<b>****Kanalisierung</b>	<b>****Ducting</b>
	<b>Confortclima</b> La stufa si spegne alla temperatura desiderata	<b>Confortclima</b> Le poêle s'éteint lorsque la température souhaitée est atteinte	<b>Confortclima</b> La estufa se apaga al llegar a la temperatura deseada	<b>Confortclima</b> Der Ofen schaltet sich bei Erreichen der gewünschten Temperatur ab	<b>Confortclima</b> The stove switches off at the desired temperature
	<b>Ventilazione</b> aria calda modulabile disattivabile	<b>Ventilation</b> d'air chaud modulable et désactivable	<b>Ventilación</b> aire caliente modulable desactivable	<b>Warmluftgebläse</b> modulierbar und deaktivierbar	<b>Hot air ventilation</b> modulable and deactivatable
	<b>Programmatore orario</b> accensione/spengimento orario desiderato	<b>Programmeur horaire</b> allumage/extinction à l'heure souhaitée	<b>Programador horario</b> encendido/apagado en el horario deseado	<b>Stundenprogrammierer</b> Ein- und Ausschalten zur gewünschten Uhrzeit	<b>Time programmer</b> desired ON/OFF times
	<b>Easy Timer</b> Semplificazione della programmazione di accensione/spengimento ritardato	<b>Easy Timer</b> Simplification de la programmation de l'allumage et de l'extinction différés	<b>Easy Timer</b> Simplificación de la programación de encendido/apagado	<b>Easy Timer</b> Vereinfachung der Programmierung von verzögertem Ein- und Ausschalten	<b>Easy Timer</b> Simplification of delayed ON/OFF programming
	<b>Relax</b> Ventilazione aria calda disattivabile	<b>Relax</b> Ventilation d'air chaud désactivable	<b>Relax</b> Ventilación aire caliente desactivable	<b>Relax</b> Deaktivierbares Warmluftgebläse	<b>Relax</b> Hot air ventilation that can be deactivated
	<b>Fire Control</b> Modulazione automatica della combustione per evitare sprechi	<b>Fire Control</b> Modulation automatique de la combustion pour éviter le gaspillage	<b>Fire Control</b> Modulación automática del aporte de combustible (consumo óptimo)	<b>Fire Control</b> Automatische Verbrennungsmodulation zur Vermeidung von Kraftstoffverschwendung	<b>Fire Control</b> Automatic combustion modulation to avoid wastage
	<b>Display</b>	<b>Panneau synoptique</b>	<b>Display</b>	<b>Bedienfeld</b>	<b>Display</b>
	<b>E-Smart</b> è il sistema innovativo, con <b>WI-FI integrato</b>	<b>E-Smart</b> est le système innovant, <b>avec WI-FI intégré</b>	<b>E-Smart</b> es el sistema innovador, <b>con WI-FI integrado</b>	<b>E-Smart</b> ist das innovative System mit <b>integriertem WLAN</b>	<b>E-Smart</b> is the innovative system with <b>integrated Wi-Fi</b>
	T Telecomando R Radiocomando <b>SMART</b>	T Télécommande R Radiocommande <b>SMART</b>	T Telecomando R Radiomando <b>SMART</b>	T Fernbedienung R Funkfernbedienung <b>SMART</b>	T Remote control R Remote control <b>SMART</b>

	* IT	* FR	* ES	* DE	* EN
	*Volume riscaldabile	*Volume de chauffe	*Volumen calentable	*Beheizbarer Rauminhalt	*Heatable volume
	**Consumo min max	**Consommation min max	**Consumo min max	**Verbrauch min max	**Consumption min max
	Potenza al focolare	Puissance au foyer	Potencia nominal	Feuerungswärmeleistung	Power (input)
	Potenza utile min-max	Puissance utile min-max	Potencia útil min-max	Leistung min-max	Power min-max
	Potenza all'acqua	Puissance eau	Potencia al agua	Wasser	Power Water
	Serbatoio pellet	Réservoir	Depósito pellet	Pelletbehälter	Pellet hopper
	Contenuto d'acqua	Contenu d'eau	Contenido de agua	Wasserinhalt	Water capacity
	Rendimento	Rendement	Rendimiento	Pelletbehälter	Efficiency
	Autonomia min-max	Autonomie min-max	Autonomía min-max	Brandduur min-max	Autonomy min-max
	Dimensioni	Dimensions	Talla	Maße von	Dimensions
	Peso con imballo	Pods avec emballage	Peso con embalaje	Gewicht	Weight with package
	***Uscita fumi ↑ SUPERIORE   ↗ POSTERIORE   → LATERALE	***Sortie fumées ↑ VERS LE HAUT   ↗ À L'ARRIÈRE   → LATÉRALE	***Salida humos ↑ SUPERIOR   ↗ TRASERA   → LATERAL	***Rauchauslässe ↑ OBEN   ↗ HINTEN   → SEITLICH	***Smoke outlet ↑ TOP   ↗ REAR   → SIDE
	Focolare G: Ghisa A: Acciaio R: Refrattario V: Vermiculite E: Ekokeram	Foyer G: Fonte A: Acier R: Réfractaire V: Vermiculite E: Ekokeram	Fuego G: Fundición A: Acero R: Refractorio V: Vermiculite E: Ekokeram	Brennraum G: Gußeisen A: Stahl R: Schamottsteine V: Vermiculite E: Ekokeram	Hearth G: Cast Iron A: Steel R: Refractory V: Vermiculite E: Ekokeram

\* IT È calcolato sulla base di una necessità di 33 kcal/m<sup>3</sup>h. Lo stesso volume può quindi variare sensibilmente in considerazione del grado di isolamento dell'abitazione, della sua esposizione, della zona climatica, ecc.). FR Le volume de chauffe est calculé sur la base d'une nécessité de 33 kcal/m<sup>3</sup>h. Ce volume peut donc varier sensiblement selon le degré d'isolation de l'habitation, son exposition, sa zone climatique, etc. ES El volumen calentable se calcula en base a una necesidad de 33 kcal/m<sup>3</sup>h. El mismo volumen puede variar sensiblemente en consideración al grado de aislamiento de la habitación, de su exposición, de la zona climática, etc. DE Das heizbare Volumen wird auf Grundlage eines Bedarfs von 33 kcal/m<sup>3</sup>h berechnet. Dies Volumen kann aber spürbar variieren und zwar in Abhängigkeit davon, wie die Wohnung isoliert wurde, wie sie liegt, in welcher Klimazone sie sich befindet etc. EN The heatable volume is calculated based on a requirement of 33 kcal/m<sup>3</sup>h. The same volume may therefore vary considerably depending on the level of insulation in the home, its exposure, the climatic area, etc.

\*\* IT Per il calcolo si è utilizzato un potere calorifico di 4,6 kW/kg per legna e di 4,8 kW/kg per il pellet. FR Pour le calcul de la consommation de combustible, on a utilisé une puissance calorifique de 4,6 kW/kg pour les granulés et de 4,8 kW/kg pour le bois. ES Para el cálculo del consumo de combustible se usa un poder calorífico de 4,6 kW/kg para la leña y 4,8kW/kg para el pellet. DE Zur Berechnung des Brennstoffverbrauchs wird ein Heizwert von 4,8 kW/kg für Pellets und 4,6 kW/kg für Holz verwendet. EN The calculation of fuel consumption assumes a calorific value of 4,8 kW/kg for pellets and 4,6 kW/kg for wood.

\*\*\* IT il Ø dell'uscita fumi non è il Ø del sistema camino che dovrà essere dimensionato secondo le norme nazionali e locali e in particolare, ma non esaustive, EN 13384, EN 1443, EN 1856, EN 1457. FR Le diamètre de la sortie des fumées n'est pas le diamètre du système de cheminée qui doit être dimensionné selon les normes nationales et locales et en particulier, mais non exhaustif, EN 13384, EN 1443, EN 1856, EN 1457. ES El Ø de la salida de humos no es el Ø del sistema de chimenea que deberá ser dimensionado de conformidad con las normas nacionales y locales y en particular, aunque no exhaustivas, EN 13384, EN 1443, EN 1856, EN 1457. DE Der Durchmesser des Rauchauslasses ist nicht der Durchmesser des Schornsteinsystems, der gemäß den nationalen und lokalen Normen und insbesondere, jedoch nicht erschöpfend, EN 13384, EN 1443, EN 1856, EN 1457 dimensioniert werden muss. EN The flue outlet Ø is not that of the chimney system, which must be sized in accordance with national and local standards and in particular, but not limited to, EN 13384, EN 1443, EN 1856, EN 1457.

\*\*\*\* IT La lunghezza della canalizzazione e la temperatura in uscita dalla bocchetta dipendono da condizioni di uso e di installazione. Sugeriamo di dimensionare il sistema di canalizzazione. FR La chaleur à la sortie d'une canalisation varie selon la longueur de celle-ci, de son installation et des conditions d'utilisation. C'est pour ces raisons que nous conseillons toujours de bien dimensionner le système de canalisation. ES La longitud de la canalización y la temperatura de la salida de aire, dependen de las condiciones de uso e instalación. Sugerimos dimensionar el sistema de canalización. DE Die Länge der Kanalisierung und die Temperatur am Auslass hängen von den Verwendungs- und Installationsbedingungen ab. Wir empfehlen eine Dimensionierung des Kanalsystems durchzuführen. EN Ducting length and vent outlet temperature, depend on the conditions of use and installation. It is therefore suggested to size the ducting system.





Berry90+	•	•	n° 1	•	R optional	•	•	•	•	•	•	•	/
Cell90+	•	•	n° 1	•	R optional	•	•	•	•	•	•	•	/
Daily130++	•	•	n° 2	•	R optional	•	•	•	•	•	•	•	/
Decor	/	/	/	/	/	/	/	/	/	/	/	/	/
Decor C	/	/	/	/	/	/	/	/	/	/	/	/	/
Dore160 H	/	/	/	•	T optional	•	•	•	•	•	/	/	•
Dub130++	•	•	n° 2	•	R optional	•	•	•	•	•	•	•	/
Entity110+	•	•	n° 1	•	R optional	•	•	•	•	•	•	•	/
Fancy	/	/	/	/	/	/	/	/	/	/	/	/	/
Firek 1	/	/	n° 2	/	/	/	/	/	/	/	/	/	/
Firek 2	/	/	n° 2	/	/	/	/	/	/	/	/	/	/
Firek 3	/	/	n° 2	/	/	/	/	/	/	/	/	/	/
Gotha80	•	•	/	•	R optional	•	•	•	•	•	•	•	/
Kappa200	/	/	/	•	/	•	•	•	•	•	/	/	/
Kappa240	/	/	/	•	/	•	•	•	•	•	/	/	/
Kappa270	/	/	/	•	/	•	•	•	•	•	/	/	/
Like80	•	•	/	•	R optional	•	•	•	•	•	•	•	/
Maison80	/	/	/	•	R optional	•	•	•	•	•	•	•	/
Maison80+	/	/	n° 1	•	R optional	•	•	•	•	•	•	•	/
Metro110+	•	•	n° 1	•	R optional	•	•	•	•	•	•	•	/
Monday150++	/	/	n° 2	•	R optional	•	•	•	•	•	•	•	/
Monday190 H	/	/	/	•	/	•	•	•	•	•	/	/	•
Monday230 H	/	/	/	•	/	•	•	•	•	•	/	/	•
Pellek110+	/	/	n° 1	•	R optional	•	•	•	•	•	/	•	/
Pellek80	/	/	/	•	R optional	•	•	•	•	•	/	•	/
Spot100 H	/	/	/	•	T	•	•	•	•	•	/	/	/
Spy110+	•	•	n° 1	•	R optional	•	•	•	•	•	•	•	/
Tweed90+	•	•	n° 1	•	R optional	•	•	•	•	•	•	•	/
Yung130++	•	•	n° 2	•	R optional	•	•	•	•	•	•	•	/
Zone80	•	•	/	•	R optional	•	•	•	•	•	•	•	/



Berry90+	/	3,7-9	/	>88	235	0,8-2	10-23,5	20	V	/	46x49x104h	125	Ø8 ↗	Ø8/13 optional
Cell90+	/	3,7-9	/	>88	235	0,8-2	7,5-17,6	15	V	/	79,5x31x105h	125	Ø8 ↑	Ø8/13
Daily130++	/	4,5-12,5	/	>88	325	1-2,8	8,2-21,9	23	V	/	63x61x120h	210	Ø8 ↗	Ø8/13 optional
Decor	/	7,2	/	82,6	190	1,9	/	/	G	/	44x45x92h	109	Ø13 ↑	/
Decor C	/	7,2	/	82,6	190	1,9	/	/	G	/	44x45x122h	134	Ø13 ↑	/
Dore160 H	/	4,8-16,2	11,8	91,6	420	1-3,7	8-30	30	A-G	12	55x57x113h	224	Ø8 ↗	/
Dub130++	/	4,5-12,5	/	>88	325	1-2,8	6,1-16,2	17	V	/	95x36x113h	155	Ø8 ↑	/
Entity110+	/	4,5-10,5	/	>88	275	1-2,4	6,9-16,2	17	V	/	95x31x107h	120	Ø8 ↑	Ø8/13
Fancy	/	4,4-9	/	78,3	235	1,2-2,5	/	/	G	/	52x52x95h	147	Ø15 ↑	/
Firek 1	/	15,2	/	78	395	4,2	/	/	A-G	/	93x63,5x155h	251	Ø20 ↑	/
Firek 2	/	15,2	/	78	395	4,2	/	/	A-G	/	95x66x155h	252	Ø20 ↑	/
Firek 3	/	15,2	/	78	395	4,2	/	/	A-G	/	95x62x155h	243	Ø20 ↑	/
Gotha80	/	3,7-7,5	/	>88	195	0,8-1,8	7,8-16,5	15	V	/	72,5x29x95,5h	105	Ø8 ↑	/
Kappa200	21,5	/	6-20,1	93,5	525	1,3-4,5	13-46	60 kg 94 l	A-G	40	55x78x131h	302	Ø8 ↗	/
Kappa240	25,8	/	6-24	92,9	625	1,3-5,4	11-46	60 kg 94 l	A-G	40	55x78x131h	335	Ø8 ↗	/
Kappa270	29,2	/	6-27	92,5	705	1,3-6,1	10-46	60 kg 94 l	A-G	40	55x78x131h	328	Ø8 ↗	/
Like80	/	3,7-7,5	/	>88	195	0,8-1,8	8,1-17,1	15	V	/	52x52x101h	90/120	Ø8 ↗	Ø8/13 optional
Maison80	/	2,5-8,2	/	88,7	215	0,6-,1,9	8-25	15	V	/	51x56x95h	151	Ø8 ↗	/
Maison80+	/	2,5-8	/	91,5	210	0,6-1,8	8-25	15	V	/	51x56x95h	154	Ø8 ↗	/
Metro110+	/	4,5-10,5	/	>88	275	1-2,4	9,4-21,9	23	V	/	54x56x119h	160	Ø8 ↗	Ø8/13 optional
Monday150++	/	4,8-14,8	/	89,9	385	1,1-3,4	9-29	32	V	/	60,5x61,5x121,5	181	Ø8 ↗	/
Monday190 H	/	5,4-19,2	15,5	91,7	500	1,2-4,4	7-25	30	A	20	60,5x62x121,5	260	Ø8 ↗	/
Monday230 H	/	5,4-22,8	19	91,6	595	1,2-5,2	6-25	30	A	20	60,5x62x121,5	260	Ø8 ↗	/
Pellek110+	/	3,5-10,5	/	89,1	275	0,8-2,5	4-14	11	G	/	73,5x49x49h	151	Ø8 ↑	/
Pellek80	/	3,5-8,3	/	89,9	215	0,8-1,9	6-14	11	G	/	73,5x49x49h	147	Ø8 ↑	/
Spot100 H	/	3,8-10,1	6,5	91,2	265	0,9-2,3	6-16	14	A-V	10	49x50x93h	150	Ø8 ↗	/
Spy110+	/	4,5-10,5	/	>88	275	1-2,4	9-21	22	V	/	55x57x120,5h	130	Ø8 ↗	Ø8/13 optional
Tweed90+	/	3,7-9	/	>88	235	0,8-2	7,3-17,1	15	V	/	50x50x101h	95	Ø8 ↗	Ø8/13 optional
Yung130++	/	4,5-12,5	/	>88	325	1-2,8	7,9-21	22	V	/	54x57x122h	155	Ø8 ↗	Ø8/13 optional
Zone80	/	3,7-7,5	/	>88	195	0,8-1,8	8,1-17,1	15	V	/	46x49x95h	95	Ø8 ↗	Ø8/13 optional

**COLORI | COULEURS | COLORES | FARBEN | COLORS**

		CERAMICA   CÉRAMIQUE   CERÁMICA   KERAMIK   CERAMIC								
		Bianco opaco Blanc opaque Blanco mate Mattweiß Matt white	Bianco Blanc Blanco Weiß White	Bianco panna Blanc crème Blanco panna Cremeweiß Cream white	Tortora Tourterelle Tortora Taubengrau Dove grey	Bordeaux Bordeaux Burdeos Bordeaux Bordeaux	Nero opaco Noir opaque Negro mate Mattschwarz Matt Black	Grigio scuro Gris foncé Gris oscuro Dunkelgrau Dark grey	Cuoio Cuir Cuero Lederer Leather	Pergamena Parchemin Pergamino Pergamentfarben Parchment
Berry90+	↗Ø8	○	/	/	●	●	/	/	/	/
Cell90+	↑Ø8	/	/	/	/	/	/	/	/	/
	↑↑↑ Ø8/13	/	/	/	/	/	/	/	/	/
Daily130++	↗Ø8	○	/	/	●	●	/	/	/	/
Decor	↑Ø13	/	/	/	●	●	/	/	●	/
Decor C	↑Ø13	/	/	/	●	●	/	/	●	/
Dub130++	↑Ø8	○	/	/	●	●	●	/	/	/
Entity110+	↑Ø8	/	/	/	/	/	/	/	/	/
	↑↑↑ Ø8/13	/	/	/	/	/	/	/	/	/
Fancy	↑Ø15	/	/	/	●	●	/	/	●	/
Gotha80	↑Ø8	/	/	/	/	/	/	/	/	/
Like80	↑Ø8	○	/	/	●	●	/	/	/	/
	↑Ø8	/	/	/	/	/	/	/	/	/
	↗Ø8	/	/	/	/	/	/	/	/	/
Maison80	↑↗Ø8	/	/	/	●	●	/	/	●	/
Maison80+	↑↗Ø8	/	/	/	●	●	/	/	●	/
Metro110+	↗Ø8	/	/	/	/	/	/	/	/	/
Spot100 H	↗Ø8	/	/	○	/	●	/	●	/	/
Spy110+	↗Ø8	/	/	/	/	/	/	/	/	/
Tweed90+	↑Ø8	/	/	/	/	/	/	/	/	/
	↗Ø8	/	/	/	/	/	/	/	/	/
Yung130++	↗Ø8	○	/	/	●	●	●	/	/	/
Zone80	↗Ø8	/	/	/	/	/	/	/	/	/
<b>CERAMICA-ACCIAIO   CÉRAMIQUE-ACIER   CERÁMICA-ACERO   KERAMIK-STAHL   CERAMIC-STEEL</b>										
Dore160 H	↗Ø8	/	○	/	/	●	/	/	/	●
Monday150++	↗Ø8	○	/	/	/	●	/	●	/	/
Monday190 H	↗Ø8	○	/	/	/	●	/	●	/	/
Monday230 H	↗Ø8	○	/	/	/	●	/	●	/	/

		ACCIAIO   ACIER   ACERO   STAHL   STEEL				VETRO   VERRE CRISTAL   GLAS   GLASS	
		Bianco perla Blanc perle Blanco perla Perlweißem Pearl white	Tortora Beige gris Tortora Taubengrau Dove grey	Bordeaux Bordeaux Bordeos Bordeaux Bordeaux	Nero opaco Noir opaque Negro mate Matt Schwarz Matt black	Bianco Blanc Blanco Weiß White	Nero Noir Negro Schwarz Black
Berry90+	↗ Ø8	/	/	/	/	/	/
Cell90+	↑ Ø8	○	●	●	●	/	/
	↑  Ø8/13	○	/	/	●	/	/
Daily130++	↗ Ø8	/	/	/	/	/	/
Decor	↑ Ø13	/	/	/	/	/	/
Decor C	↑ Ø13	/	/	/	/	/	/
Dub130++	↑ Ø8	/	/	/	/	/	/
Entity110+	↑ Ø8	○	●	●	●	/	/
	↑  Ø8/13	○	/	/	●	/	/
Fancy	↑ Ø15	/	/	/	/	/	/
Gotha80	↑ Ø8	○	●	●	●	/	/
Like80	↑ Ø8	/	/	/	/	/	/
	↑ Ø8	○	●	●	●	/	/
	↗ Ø8	○	/	/	●	/	/
Maison80	↑ ↗ Ø8	/	/	/	/	/	/
Maison80+	↑ ↗ Ø8	/	/	/	/	/	/
Metro110+	↗ Ø8	○	●	●	●	/	/
Spot100 H	↗ Ø8	/	/	/	/	/	/
Spy110+	↗ Ø8	○	●	●	●	○	●
Tweed90+	↑ Ø8	○	●	●	●	○	●
	↗ Ø8	/	/	/	●	○	/
Yung130++	↗ Ø8	/	/	/	/	/	/
Zone80	↗ Ø8	○	●	●	●	/	/

#### \* IT | CERTIFICAZIONI

I prodotti a legna e a pellet, oltre alla marcatura CE, in base alle norme:

EN 13229 - focolari chiusi a legna

EN 13240 - stufe a legna

EN 14785 - stufe a pellet

EN 303-5 - caldaie

secondo le necessità, rispettano i criteri di:

FLAMME VERTE - certificazione francese di qualità

BimSchV - requisiti per il mercato tedesco

BAFA - ministero dell'energia tedesco

EKO SKLAD - ministero dell'energia sloveno

#### \* FR | CERTIFICATION

Les produits, en plus de la norme CE, en fonction des normes:

EN 13229 Foyers - EN 13240 Poêles à bois

EN 14785 Poêles à pellet - EN 303-5 Chaudières

selon les nécessités, respectent les critères de:

FLAMME VERTE: Marque de certification française de qualité

Blmsch: Renseignements allemands pour les appareils de

chauffage domestiques

BAFA: Du ministère de l'énergie Allemande

EKO SKLAD: Ministère slovène de l'énergie

#### \* ES | CERTIFICAZIONI

Los productos, además del marcaje CE, en base a las normas:

EN 13229 - Hogares de leña

EN 13240 - Estufas de leña

EN 14785 - Estufas de pellet

EN 303-5 - Calderas

según las necesidades, respetan los criterios de:

FLAMME VERTE - Certificación francesa de calidad

BimSchV - Requisitos para el mercado alemán

BAFA - Ministerio de Energía alemán

EKO SKLAD - Ministerio de Energía esloveno

#### \* DE | BESCHEINIGUNGEN

Die Produkte, zusätzlich zur CE-Kennzeichnung, laut Normen:

EN 13229 Kamineisätze - EN 13240 Kaminöfen

EN 14785 Pellet-Kaminöfen - EN 303-5 Heizkessel

Entsprechen, je nach Bedarf, folgenden Kriterien:

Flamme Verte: Französisches Zertifizierungszeichen der Qualität

Blmsch: Deutsche Anforderungen an Haushaltsfeuerungsgeräte

BAFA: Deutsche Förderung von Energie und Klimaschutz

EKO SKLAD: Slowenischen Ministerium für Energie

#### \* EN | CERTIFICATION

Products, in addition to the CE marking and according to rules:

EN 13229 Fireplaces - EN 13240 Wood-stoves

EN 14785 Pellet stoves - EN 303-5 Boilers

in accordance with need, shall comply with the criteria set by:

Flamme Verte: French quality certification

Blmsch: German requirement for domestic heating appliance

BAFA: German Energy Ministry

EKO SKLAD: Slovenian Ministry of Energy.



ECODESIGN

#### \* IT |

Definisce i requisiti minimi che i prodotti a combustibile solido, utilizzati per il riscaldamento, devono rispettare per poter essere immessi nel mercato europeo: caldaie dal 2020, altri prodotti dal 2022.

#### \* FR |

Définit les exigences minimales que les produits à combustible solide utilisés pour le chauffage doivent respecter pour pouvoir être commercialisés sur le marché européen. Chaudières à partir du 2020, pour tous les autres produits à partir du 2022.

#### \* ES |

Defini los requisitos mínimos que los productos de combustible sólido, usan para calentar, deben respetar, para poder ser introducidos en el mercado europeo: calderas desde 2020, otros productos desde el 2022.

#### \* DE |

Sie legt die Mindestanforderungen fest, die zum Heizen eingesetzte Festbrennstoff-Geräte erfüllen müssen, damit sie auf dem europäischen Markt in Verkehr gebracht werden können. Heizkessel ab 2020, für alle anderen Produkte ab 2022.

#### \* EN |

This defines the minimum requirements that appliances burning solid fuels, used for heating, need to comply with in order to be admitted to the European market, boilers from 2020, for all other products from 2022.

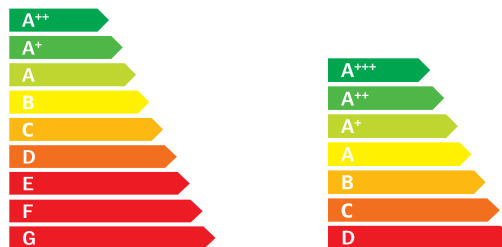

#### \* IT | CLASSI ENERGETICHE

I prodotti **EK63** dispongono della etichettatura energetica secondo i regolamenti dell' UE 2015-1186/1187/1188.

#### \* FR | CLASSES ÉNERGÉTIQUES

Les produits **EK63** disposent d'un étiquetage énergétique conforme aux règlements de l'UE 2015-1186/1187/1188.

#### \* ES | CLASE ENERGETICA

Los productos **EK63** disponen de la etiqueta energética según el reglamento UE 2015-1186/1187/1188.

#### \* DE | ENERGIEKLASSEN

Alle **EK63**-Produkte fallen in die Energieeffizienzklassen, Nach EU-Richtlinien 2015-1186/1187/1188.

#### \* EN | ENERGY EFFICIENCY CLASSES

All **EK63** products meet the criteria of energy efficiency classes, according to the UE 2015-1186/1187 Regulation.

#### \* IT | AGEVOLAZIONI

- Detrazione fiscale per ristrutturazione (BONUS CASA)
- Detrazione fiscale per riqualificazione energetica (ECOBONUS)
- Detrazione SUPERBONUS 110%
- SCONTO in fattura e cessione del credito per le detrazioni di cui sopra (per BONUS CASA valutare il tipo di intervento)



CONTO TERMICO 2.0

#### \* IT | CLASSI AMBIENTALI

Il D.M. 186 del Novembre 2017 ha introdotto una classificazione che assegna n.5 diverse classi ambientali (denominate "STELLE") ai generatori di calore.



Classe ambientale DM 186

#### \* FR | FLAMME VERTE



Defiscalisation pour l'achat des cheminées, foyers chaudières, thermopoeles, poeles a granule et bois.

#### \* FR | AIDES DE L'ÉTAT

Pour informations voir:

<https://www.edilkamin.com/fr/aides-de-letat>

#### \* FR | AIDES PUBLIQUES POUR LE BELGIQUE



Prime à l'Energie - Région Wallonne

Pour informations voir:

<https://www.edilkamin.com/fr/aides-de-letat>



<b>Berry90+</b>	<b>38-41</b>
<b>Cell90+</b>	<b>54-57</b>
<b>Daily130++</b>	<b>46-49</b>
<b>Decor</b>	<b>80-81</b>
<b>Decor C</b>	<b>82-83</b>
<b>Dore160 H</b>	<b>74-75</b>
<b>Dub130++</b>	<b>62-65</b>
<b>Entity110+</b>	<b>58-61</b>
<b>Fancy</b>	<b>84-85</b>
<b>Firek 1</b>	<b>86-89</b>
<b>Firek 2</b>	<b>86-89</b>
<b>Firek 3</b>	<b>86-89</b>
<b>Gotha80</b>	<b>50-53</b>
<b>Kappa200</b>	<b>78-79</b>
<b>Kappa240</b>	<b>78-79</b>
<b>Kappa270</b>	<b>78-79</b>
<b>Like80</b>	<b>12-17</b>
<b>Maison80</b>	<b>66-67</b>
<b>Maison80+</b>	<b>66-67</b>
<b>Metro110+</b>	<b>42-45</b>
<b>Monday150++</b>	<b>68-69</b>
<b>Monday190 H</b>	<b>76-77</b>
<b>Monday230 H</b>	<b>76-77</b>
<b>Pellek80</b>	<b>70-71</b>
<b>Pellek110+</b>	<b>70-71</b>
<b>Spot100 H</b>	<b>72-73</b>
<b>Spy110+</b>	<b>24-29</b>
<b>Tweed90+</b>	<b>18-23</b>
<b>Yung130++</b>	<b>30-33</b>
<b>Zone80</b>	<b>34-37</b>
<b>More infomations</b>	<b>90-97</b>

#### **EDILKAMIN S.p.A.**

**\* IT** | Si riserva la facoltà di modificare in qualunque momento, senza preavviso, le caratteristiche tecniche ed estetiche degli elementi illustrati e declina ogni responsabilità per eventuali errori di stampa presenti. Le immagini sono puramente indicative. Per una corretta installazione seguire quanto riportato sulle schede tecniche.

**\* FR** | Se réserve la faculté de modifier à tout moment, sans préavis, les caractéristiques techniques et esthétiques des éléments illustrés et décline toute responsabilité pour d'éventuelles erreurs d'impression présentes dans le catalogue.

**\* ES** | Se reserva la facultad de modificar en cualquier momento, sin previo aviso, las características técnicas y estéticas de los elementos ilustrados declina cualquier responsabilidad por posibles errores de impresión presentes en el catálogo.

**\* DE** | Behält sich das Recht vor, ohne Vorankündigung die technischen und ästhetischen Merkmale der im vorliegenden Katalog abgebildeten Elemente jederzeit zu ändern. Er übernimmt keine Haftung für eventuelle Druckfehler.

**\* EN** | Reserves the right to change the technical and aesthetic specifications of the components illustrated in this catalogue, at any time and without prior notice and declines all responsibility for any printing errors in this catalogue.

# IL FUOCO 5.0

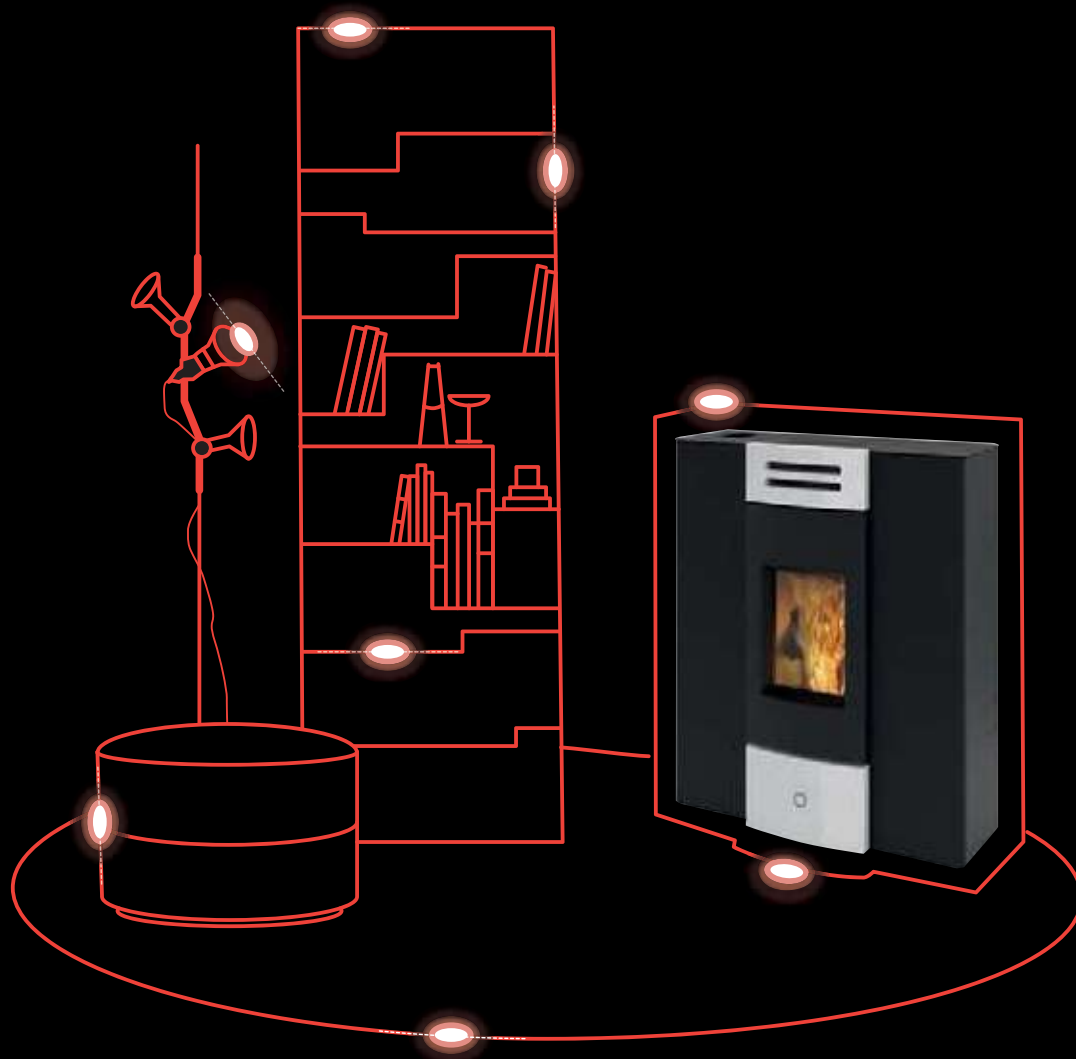

[www.ek-63.com](http://www.ek-63.com)

#iosonoilfuoco

 **EK 63**  
Smart Fire



IT [mail@edilkamin.com](mailto:mail@edilkamin.com)  
FR | DE | EN [export@edilkamin.com](mailto:export@edilkamin.com)  
ES [edilkaminiberica@edilkamin.com](mailto:edilkaminiberica@edilkamin.com)

Follow us   

945805 1.04.22/A

